

## Ultra-small package High-precision Voltage Detector with delay circuit, ME2805 Series

### General Description

**ME2805 Series** is a series of high-precision voltage detectors with a built-in delay time generator of fixed time developed using CMOS process. Internal oscillator and counter timer can delay the release signal without external parts. Detect voltage is extremely accurate with minimal temperature drift. CMOS output configurations are available.

### Selection Guide

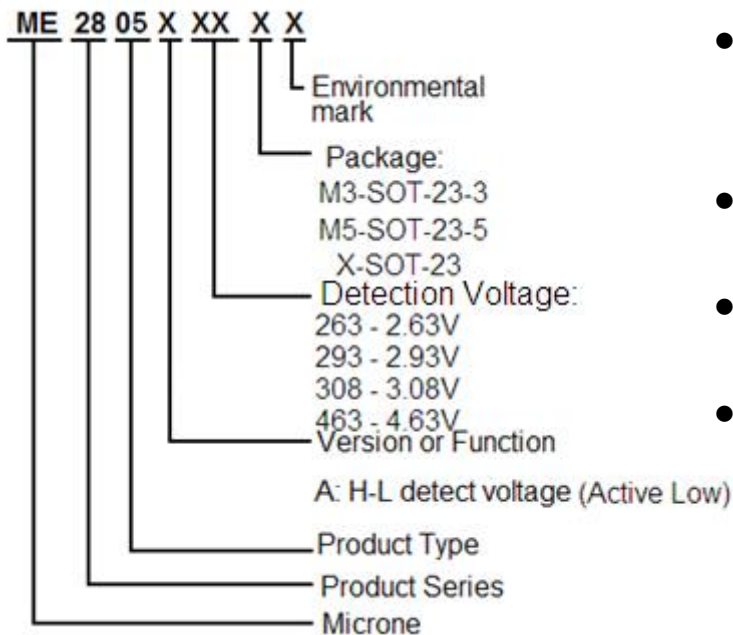

### Features

- Highly accuracy:  $\pm 2\%$
- Low power consumption: TYP 0.9 $\mu$ A ( $V_{DD}=3V$ )
- Detect voltage range: 1.0V~6.5V in 0.1V increments
- Operating voltage range: 0.7V~7V
- Detect voltage temperature characteristics:  
TYP $\pm 100$ ppm/ $^{\circ}$ C
- Output configuration: CMOS
- Package: SOT-23-3, SOT-23-5, SOT-23

### Typical Application

- Power monitor for portable equipment such as notebook computers, digital still cameras, PDA, and cellular phones
- Constant voltage power monitor for cameras, video equipment and communication devices.
- Power monitor for microcomputers and reset for CPUs.
- System battery life and charge voltage monitors

### Typical Application Circuit

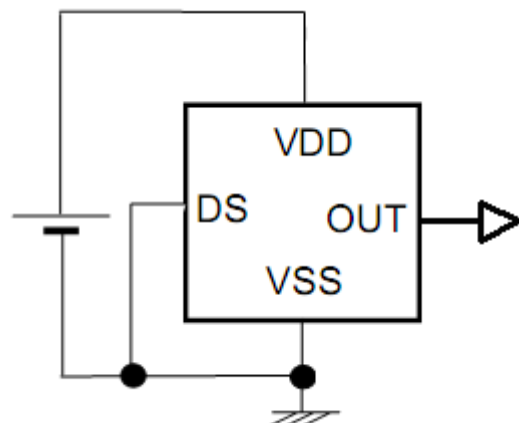

## Pin Configuration

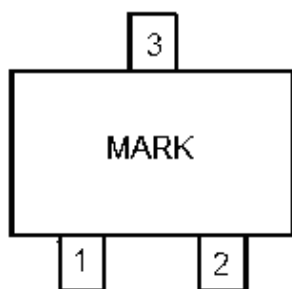

SOT-23-3 / SOT-23

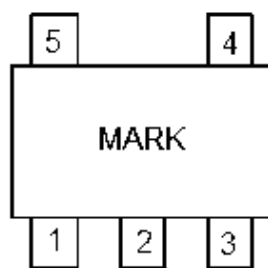

SOT-23-5

## Pin Assignment

PIN Number	Pin Name	Function
SOT-23-3/SOT-23		
1	VSS	Ground
2	VOUT	Output Voltage
3	VDD	Input Voltage

PIN Number	Pin Name	Function
SOT-23-5		
1	DS	ON/OFF switch for delay time
2	VSS	Ground
3	NC	No Connection
4	VOUT	Output Voltage
5	VDD	Input Voltage

## Block Diagram

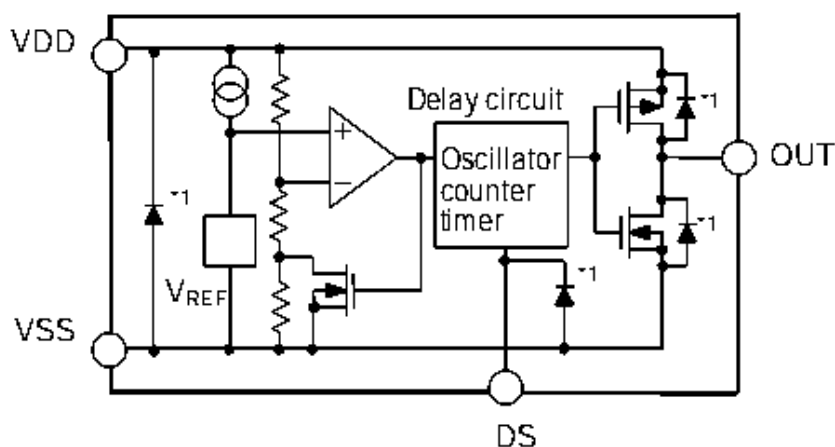

\*1. Parasitic diode

## Absolute Maximum Ratings

PARAMETER		SYMBOL	RATINGS	UNITS
V <sub>DD</sub> Input Voltage		V <sub>DD</sub>	8	V
Output Current		I <sub>OUT</sub>	50	mA
Output Voltage	CMOS	V <sub>OUT</sub>	V <sub>SS</sub> -0.3~ V <sub>DD</sub> +0.3	V
Continuous Total Power Dissipation	SOT-23-3	Pd	300	mW
	SOT-23-5			
Operating Ambient Temperature		T <sub>Opr</sub>	-40~+85	°C
Storage Temperature		T <sub>stg</sub>	-40~+125	°C
Soldering temperature and time		T <sub>solder</sub>	260°C, 10s	
ESD		MM	400	V
		HBM	4000	V

## Electrical Characteristics:

(-V<sub>DET</sub>(S)=1.0V to 6.5V±2% , Ta=25°C , unless otherwise noted)

Parameter	Symbol	Conditions	Min.	Typ	Max.	Units	Test circuit
Detect Voltage	-VDET	-	-VDET (S) x0.98	-VDET(S)	-VDET(S) x1.02	V	1
Hysteresis Range	VHYS	-	0.03	0.06	0.1	V	
Supply Current	ISS	VDD=3V (below 2.5V)	-	0.9	1.5	uA	2
		VDD=5V (2.5V-4.5V)	-	1.4	2.8		
		VDD=7V (4.5V-6.5V)	-	1.8	3.6		
Output Current	I <sub>out</sub> N-ch	VDS=0.5V VDD=0.7V	0.01	0.19	--	mA	3
	I <sub>out</sub> P-ch	VDS=0.5V VDD=7V	1.7	3.4	--	mA	4
Operating voltage	VDD	-	0.7	-	7	V	1
Delay time	Td1	VDD=-VDET+1V DS low	130	200	290	ms	1
	Td2	VDD=-VDET+1V DS high	110	220	330	us	5
Temperature characteristics	$\frac{\Delta -VDET}{\Delta Ta \bullet -VDET}$	$\Delta Ta = -40^{\circ}C \sim 85^{\circ}C$	-	±100	±350	ppm/°C	1

- Note: 1、-VDET(S) : Specified Detection Voltage value  
 2、-VDET : Actual Detection Voltage value  
 3、Release Voltage: +VDET=-VDET+VHYS

Test Circuits:

1.

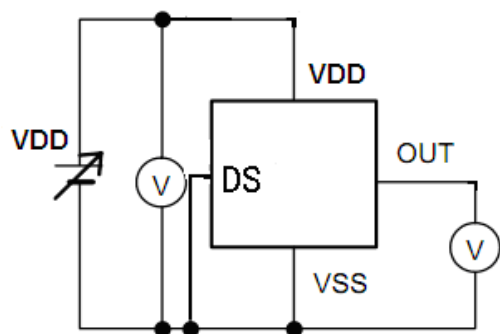

2.

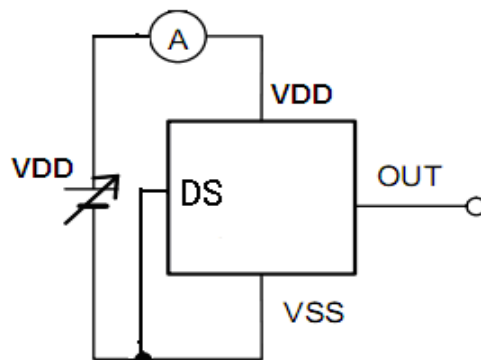

3.

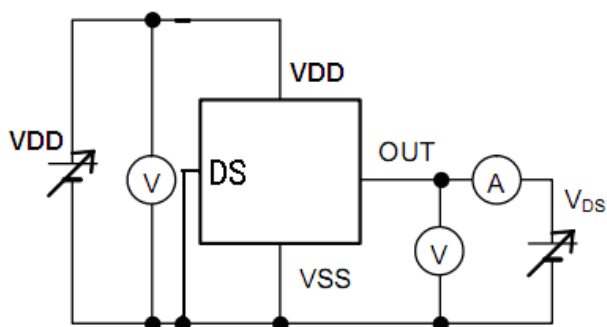

4.

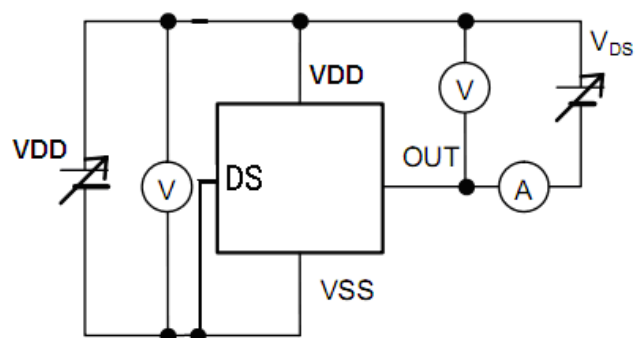

5.

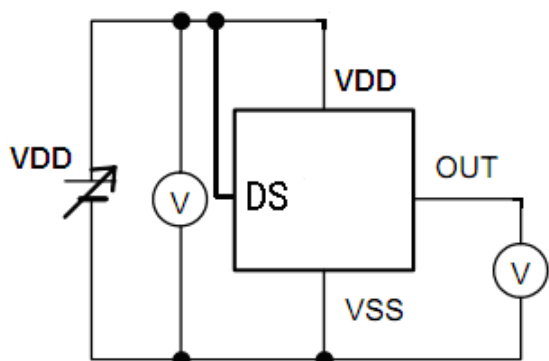

## Functional Description:

### 1. Basic Operation: CMOS Output (Active Low)

1-1. When the power supply voltage (VDD) is higher than the release voltage (+VDET), the Nch transistor is OFF and the Pch transistor is ON to provide VDD (high) at the output. Since the Nch transistor N1 in Figure 1 is OFF,

$$\frac{(R_B + R_C) \cdot VDD}{R_A + R_B + R_C}$$

the comparator input voltage is

1-2. When the VDD goes below +VDET, the output provides the VDD level, as long as VDD remains above the detection voltage (-VDET). When the VDD falls below -VDET (point A in Figure 2), the Nch transistor becomes ON, the Pch transistor becomes OFF, and the VSS level appears at the output. At this time the Nch

$$\frac{R_B \cdot VDD}{R_A + R_B}$$

transistor N1 in Figure 1 becomes ON, the comparator input voltage is changed to

1-3. When the VDD falls below the minimum operating voltage, the output becomes undefined, or goes to VDD when the output is pulled up to VDD.

1-4. The VSS level appears when VDD rises above the minimum operating voltage. The VSS level still appears even when VDD surpasses the -VDET, as long as it does not exceed the release voltage +VDET.

1-5. When VDD rises above +VDET (point B in Figure 2), the Nch transistor becomes OFF and the Pch transistor becomes ON to provide VDD at the output. The VDD at the OUT pin is delayed for Td due to the delay circuit.

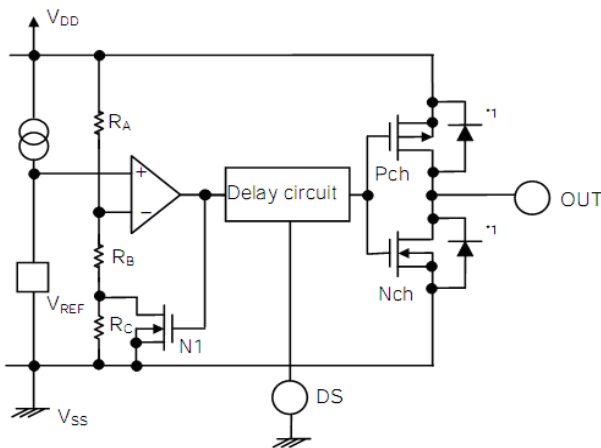

\*1. Parasitic diode

Figure 1 Operation 1

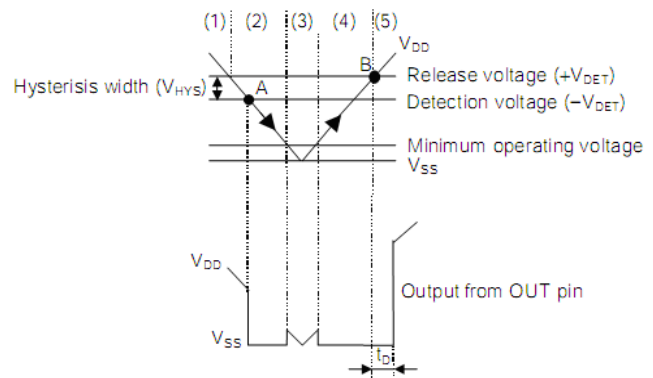

Figure 2 Operation 2

## 2. Delay Circuit

### 2-1. Delay Time

The delay circuit delays the output signal from the time at which the power voltage ( $V_{DD}$ ) exceeds the release voltage ( $+V_{DET}$ ) when  $V_{DD}$  is turned on. The output signal is not delayed when the  $V_{DD}$  goes below the detection voltage ( $-V_{DET}$ ). (Refer to Figure 2.) The delay time ( $t_D$ ) is a fixed value that is determined by a built-in oscillation circuit and counter.

### 2-2. DS Pin (ON/OFF Switch Pin for Delay Time)

The DS pin should be connected to Low or High. When the DS pin is High, the output delay time becomes short since the output signal is taken from the middle of counter circuit (Refer to Figure 3).

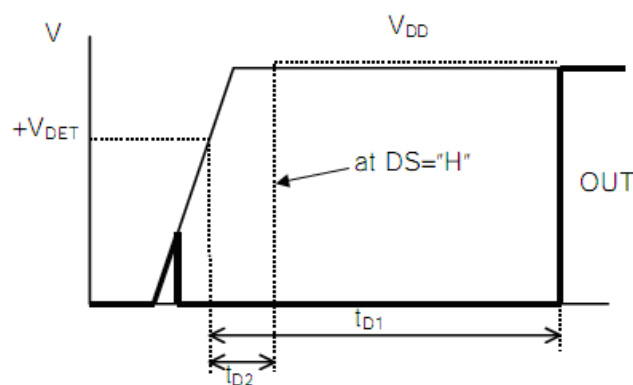

Figure 3

## Directions for use:

- 1、 Please use this IC within the stated maximum ratings. Operation beyond these limits may cause degrading or permanent damage to the device.
- 2、 When a resistor is connected between the  $V_{DD}$  pin and the input with CMOS output configurations, oscillation may occur as a result of voltage drops at  $R_{IN}$  if load current ( $I_{OUT}$ ) exists. (refer to the Oscillation Description(1) below)
- 3、 When a resistor is connected between the  $V_{DD}$  pin and the input with CMOS output configurations, oscillation may occur as a result of through current at the time of voltage release even if load current ( $I_{OUT}$ ) does not exist. (refer to the Oscillation Description(2) below)
- 4、 With a resistor connected between the  $V_{DD}$  and the input, detect and release voltage will rise as a result of the IC's supply current flowing through the  $V_{DD}$  pin.
- 5、 In order to stabilize the IC's operations, please ensure that  $V_{DD}$  pin's input frequency's rise and fall times are more than several  $\mu$  Sec/V.

---

## Oscillation Description:

### 1、 Output current oscillation with the CMOS output configuration

When the voltage applied at IN rises, release operations commence and the detector's output voltage increase. Load current( $I_{OUT}$ ) will flow at  $R_L$ . Because a voltage drop( $R_{IN} * I_{OUT}$ ) is produced at the  $R_{IN}$  resistor, located between the input(IN) and the  $V_{DD}$  pin. The load current will flow via the IC's pin. The voltage drop will also lead to a fall in the voltage level at the  $V_{DD}$  pin. When the  $V_{DD}$  pin voltage level falls below the detect voltage level, detect operations will commence. Following detect operations, load current flow will cease and since voltage drop at  $R_{IN}$  will disappear, the voltage level at the  $V_{DD}$  pin will rise and release operations will begin over again. Oscillation may occur with this "release-detect-release" repetition. Further, this condition will also appear via means of a similar mechanism during detect operations.

### 2、 Oscillation as a result of through current

Since the ME2805 series are CMOS IC's, through current will flow when the IC's internal circuit switching operates(during release and detect operations). Consequently, oscillation is liable to occur as a result of drops in voltage at the through current's resistor( $R_{IN}$ ) during release voltage operations.(refer to diagram 2) since hysteresis exists during detect operations, oscillation is unlikely to occur.

## Type Characteristics

### 1、 SUPPLY CURRENT VS. AMBIENT TEMPERATURE

VDD=5V,-VDET=2.63V

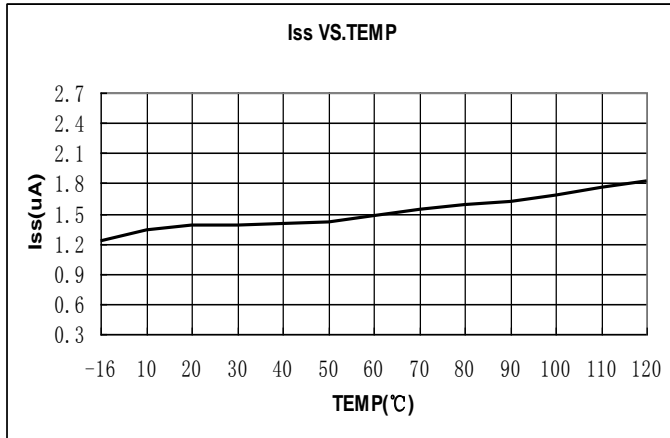

VDD=2.5V,-VDET=2.63V

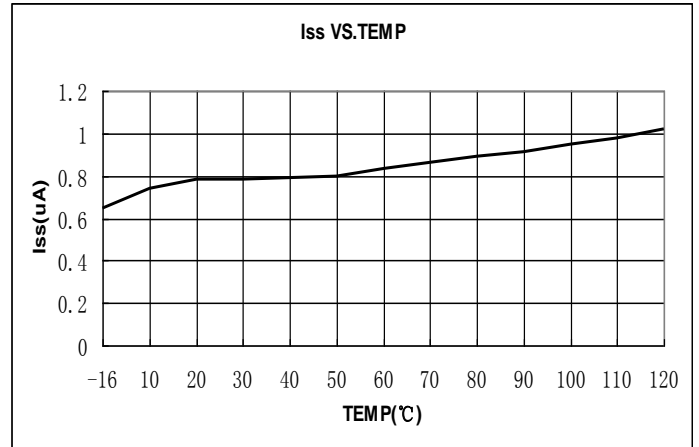

### 2、 SUPPLY CURRENT VS. INPUT VOLTAGE

-VDET=2.63V (T=25°C)

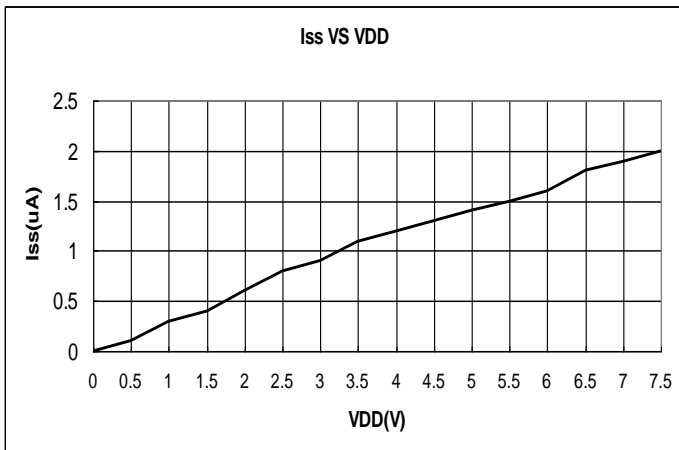

### 3、 DETECT,RELEASE VOLTAGE VS. AMBIENT TEMPERATURE

-VDET=2.63V

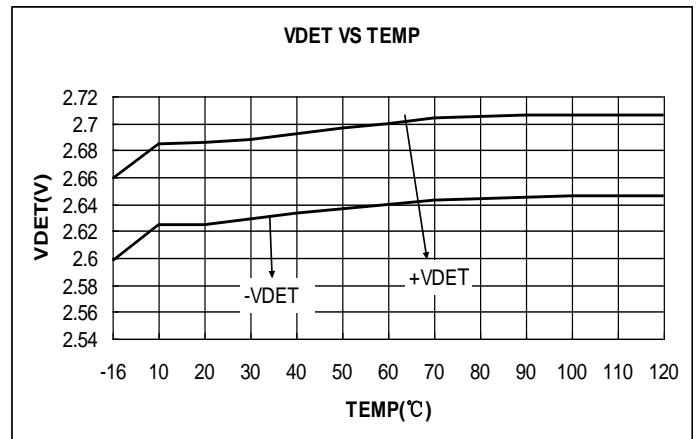

### 4、 OUTPUT CURRENT VS. INPUT VOLTAGE

N-ch VDS=0.5V,-VDET=2.63V

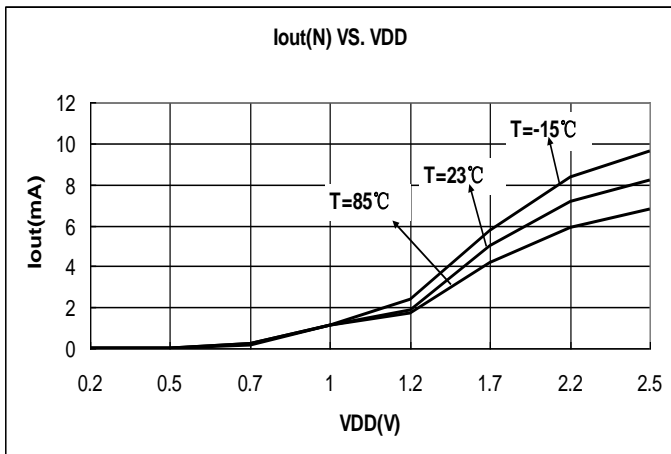

P-ch VDS=0.5V,-VDET=2.63V

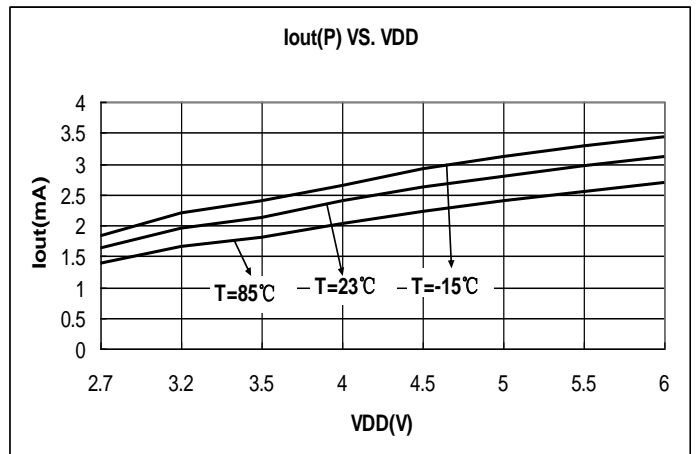



Package Information

• SOT-23-3

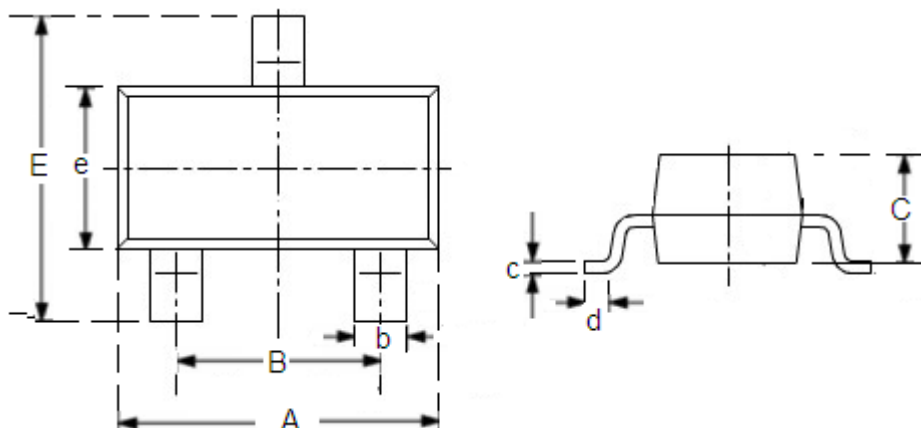

DIM	Millimeters		Inches	
	Min	Max	Min	Max
A	2.7	3.1	0.1063	0.122
B	1.7	2.1	0.0669	0.0827
b	0.35	0.5	0.0138	0.0197
C	1.0	1.2	0.0394	0.0472
c	0.1	0.25	0.0039	0.0098
d	0.2	-	0.0079	-
E	2.6	3.0	0.1023	0.1181
e	1.5	1.8	0.059	0.0708

• SOT-23

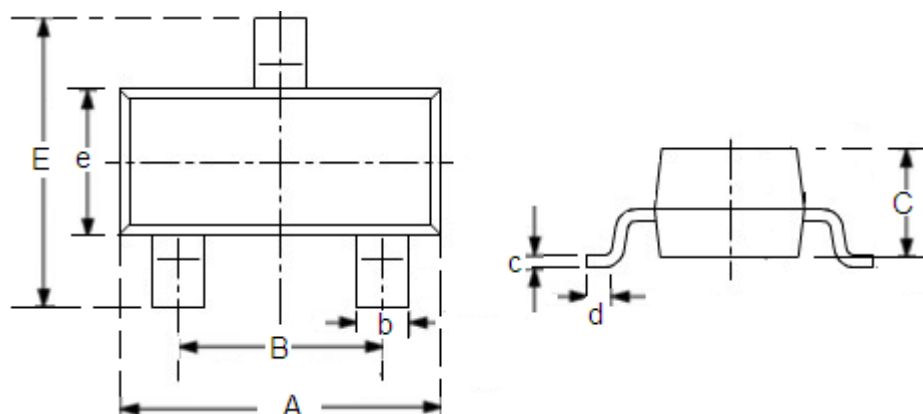

DIM	Millimeters		Inches	
	Min	Max	Min	Max
A	2.7	3.1	0.1063	0.122
B	1.7	2.1	0.0669	0.0827
b	0.35	0.5	0.0138	0.0197
C	1.0	1.2	0.0394	0.0472
c	0.1	0.25	0.0039	0.0098
d	0.2	-	0.0079	-
E	2.1	2.64	0.0827	0.1039
e	1.2	1.4	0.0472	0.0551

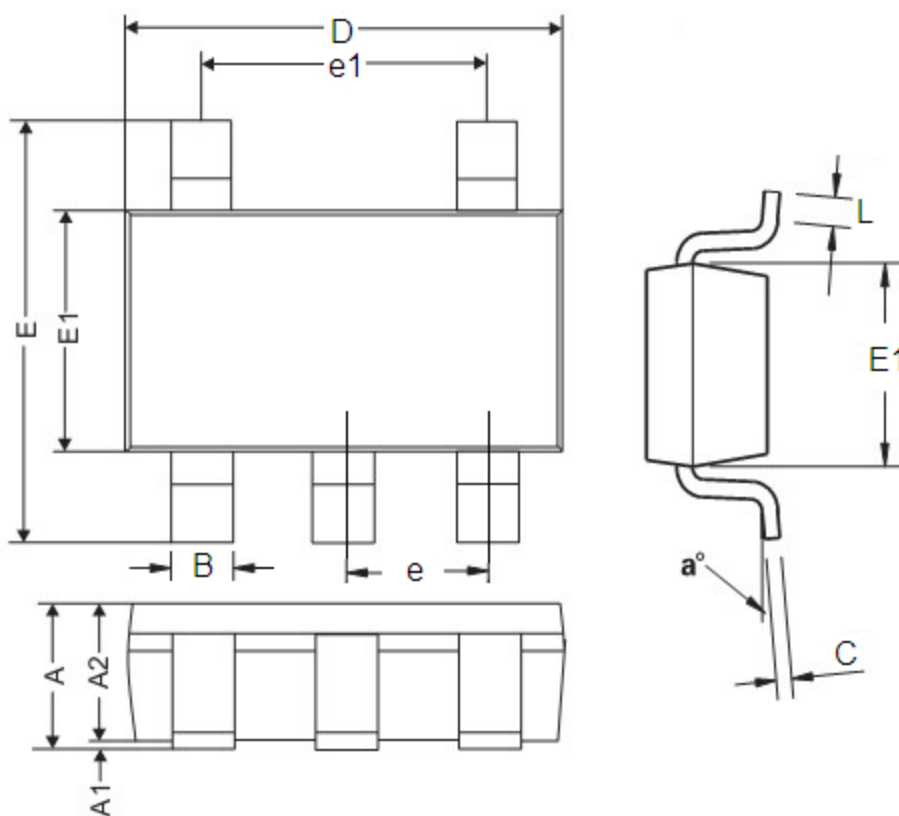

DIM	Millimeters		Inches	
	Min	Max	Min	Max
A	0.9	1.45	0.0354	0.0570
A1	0	0.15	0	0.0059
A2	0.9	1.3	0.0354	0.0511
B	0.2	0.5	0.0078	0.0196
C	0.09	0.26	0.0035	0.0102
D	2.7	3.10	0.1062	0.1220
E	2.2	3.2	0.0866	0.1181
E1	1.30	1.80	0.0511	0.0708
e	0.95REF		0.0374REF	
e1	1.90REF		0.0748REF	
L	0.10	0.60	0.0039	0.0236
a°	0°	30°	0°	30°

- The information described herein is subject to change without notice.
- Nanjing Micro One Electronics Inc is not responsible for any problems caused by circuits or diagrams described herein whose related industrial properties, patents, or other rights belong to third parties. The application circuit examples explain typical applications of the products, and do not guarantee the success of any specific mass-production design.
- Use of the information described herein for other purposes and/or reproduction or copying without the express permission of Nanjing Micro One Electronics Inc is strictly prohibited.
- The products described herein cannot be used as part of any device or equipment affecting the human body, such as exercise equipment, medical equipment, security systems, gas equipment, or any apparatus installed in airplanes and other vehicles, without prior written permission of Nanjing Micro One Electronics Inc.
- Although Nanjing Micro One Electronics Inc exerts the greatest possible effort to ensure high quality and reliability, the failure or malfunction of semiconductor products may occur. The user of these products should therefore give thorough consideration to safety design, including redundancy, fire-prevention measures, and malfunction prevention, to prevent any accidents, fires, or community damage that may ensue.